



REDEFINING
THE WAY

-



User Manual DPPRO

Warning: Do not use electric leisure vehicles until you carefully read the user manual to understand their performance, And please keep the user manual properly.



Welcome to the DIMENTRO family!

We are delighted that you have chosen the DP-03 electric two-wheeler. To assist you in operating the DP-03 correctly and safely, please follow our guidance below. Safety is paramount, so we urge you to read this manual thoroughly before using your vehicle and adhere to the following requirements:

Gain a comprehensive understanding of the information provided in the manual, encompassing instructions, precautions, and warnings.

Familiarize yourself with the operational procedures and emergency protocols.

Take note of the warning labels affixed to the DP-03.

DIMENTRO will not be held responsible for any issues arising from unauthorized modifications, the use of non-original parts, or the installation of components that could impact performance and safety.

Should you encounter any difficulties while using this electric vehicle, please reach out to your local dealers or distributors for assistance.

DIMENTRO is committed to serving you. We hope you enjoy a pleasant journey!

Safety instruction

To ensure your and others' safety, please adhere to the following guidelines meticulously:

A. Product Familiarization:

- Read this product manual thoroughly before use. Ensure you comprehend the product's characteristics and functionalities.

B. Road Safety:

- Obey all traffic rules and refrain from using smartphones while driving. This applies to all modes of transportation, including electric vehicles (EVs).

C. Original Parts Policy:

- It is strictly prohibited to use non-original components from third-party sources or to disassemble and modify the EV without authorization. Any loss or damage incurred due to such actions will be solely your responsibility, and DIMENTRO will cease all guarantees for this EV.

D. Product Variations:

- Keep in mind that due to continuous improvements, the EV you receive may slightly differ from the descriptions in the manual. Therefore, always refer to your actual EV for accurate information. For any uncertainties regarding usage, maintenance, or assembly, please contact our dealers or distributors.

E. Personal Protective Equipment (PPE):

- For your safety, wear a helmet, gloves, and other necessary protective gear while driving this product. Avoid loose clothing, as it can compromise your safety and comfort.

F. Pre-Ride Check:

- Before embarking on your ride, ensure that you are physically fit and well-rested. Avoid driving when fatigued to maintain optimal control of the product.
- G. Weather Precautions:
- In rainy or snowy or other extreme weather conditions, reduce your speed. Additionally, increase your braking distance when necessary to ensure safety.
- H. Parking Regulations:
- Do not park electric motorcycles in lobbies, escape stairs, life passageways, or safety exits. These areas are reserved for emergency use only.
- I. Charging & Storage:
- Never charge or park your EV inside residential buildings. When charging, ensure the electric motorcycle is situated away from combustible materials. Promptly disconnect the charger once the battery is fully charged to prevent overcharging.

Product Parameters

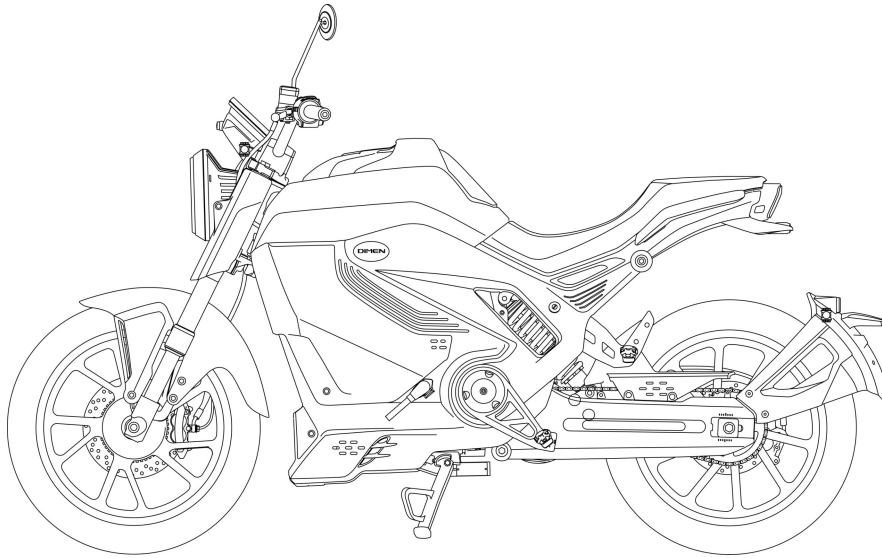

Model Name	DP-03
Homologation	EEC(EU)-L3e
Max Speed	115 km/h
Max Range	130 km(Two batteries)
Max Climb Capacity	$\geq 30\%$ / 16.7°
Max loading Weight	320 kg
Waterproof level	IP65

Battery Type	Removable NCM Lithium
Battery Cell	Samsung 21700
Battery Capacity	72V38Ah
Battery Weight	17.3 kg
Second Battery	√
Motor Type	Centralized Motor
Motor Rated Power	9.5 kW
Motor Peak Power	11 kW
Max Torque	260 N.m
Controller Type	FOC
Charger Input Voltage	220V/110V
Charger Power	72V10A(Optional fast charger 15A)
Charging Time	3.8h(Optional 2.5h)
Unlocking Type	Remote control+NFC+Key
Brake type	ABS
Display type	TFT
USB	√
Vehicle Size	2105*815*1120 mm
Ground Clearance	164 mm
Tyre Size	Fr.110/70-17 / Re. 140/70-17
Tire pressure monitoring	√
Communication Protocol	CAN-bus

Components instruction

A. Description of Components

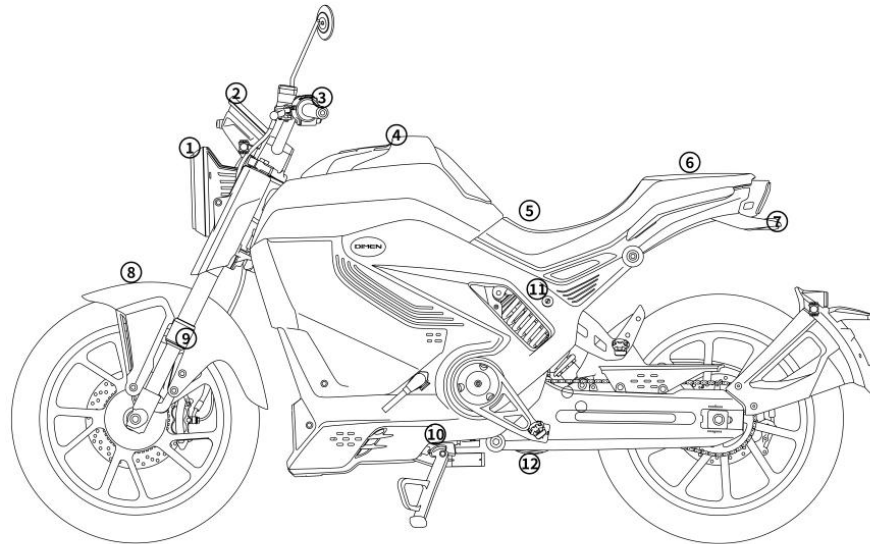

① Headlight ② instrument ③ Left handle ④ Battery holder cover ⑤ Cushion ⑥ Rear light ⑦ Rear fender ⑧ Front fender ⑨ Front suspension ⑩ Side stand ⑪ Lock ⑫ Motor

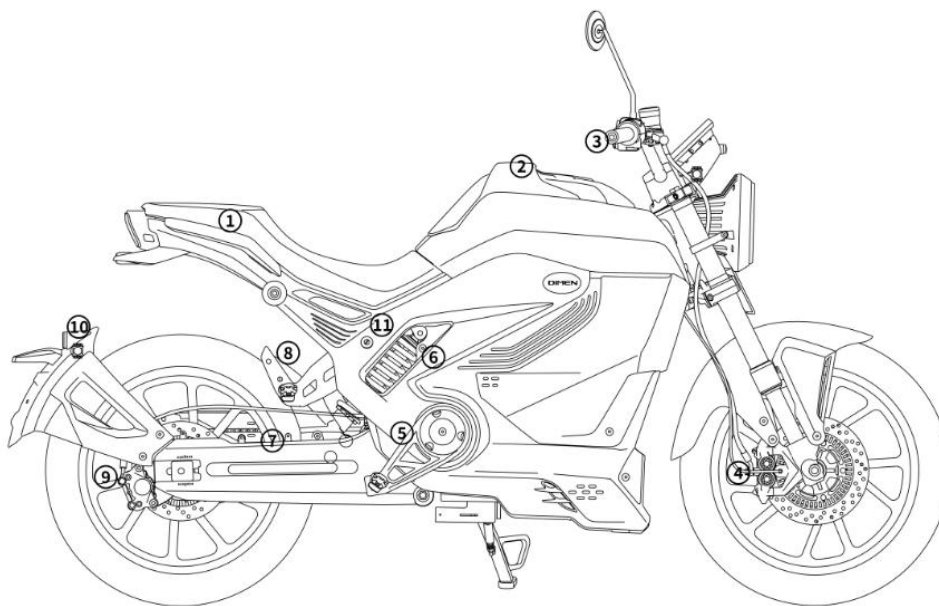

- ①: Rear armrest ②: NFC sensing area ③: Throttle ④: Front brake caliper ⑤: Pedal ⑥: Rear suspension
⑦: Cover---Swing-arm ⑧: Passenger pedal ⑨: Rear brake caliper ⑩: Reflector ⑪: Cushion lock

B. Instrument

This Manual is for reference only. The instrument may be different from that described in this manual due to system version upgrade. The actual version shall prevail.

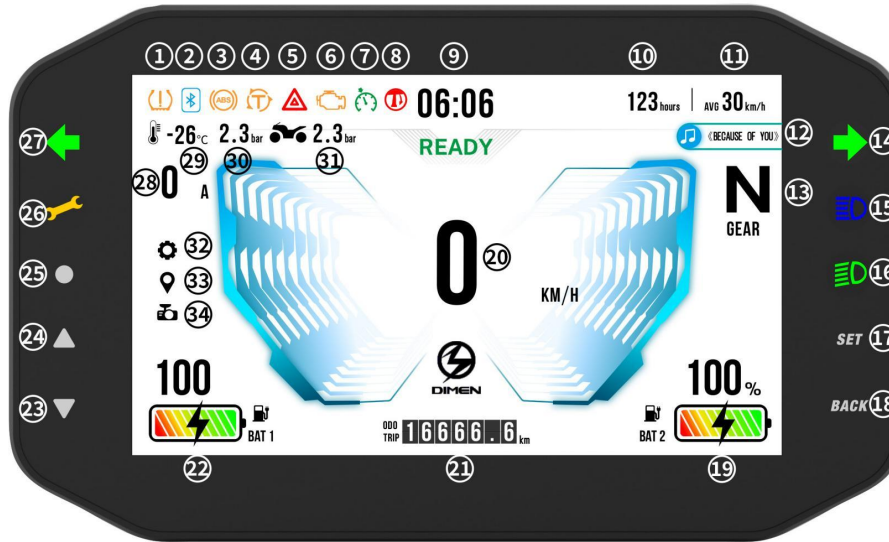

Day mode

①Braking ②Bluetooth ③ABS ④TCS ⑤Double flash ⑥Motor ⑦Cruise control ⑧Side Stand ⑨Clock ⑩Driving time
⑪Average speed ⑫Music/coming call ⑬Gear ⑭right winker ⑮high beam ⑯low beam ⑰Setting ⑱Back ⑲Battery
2 ⑳Speed ㉑ODO ㉒Battery 1 ㉓Down ㉔Up ㉕Enter ㉖Engine check ㉗Left winker ㉘Current ㉙Temperature ㉚
Front tyre pressure ㉛Rear tyre pressure ㉜Setting ㉝Navigation ㉞Dash-cam

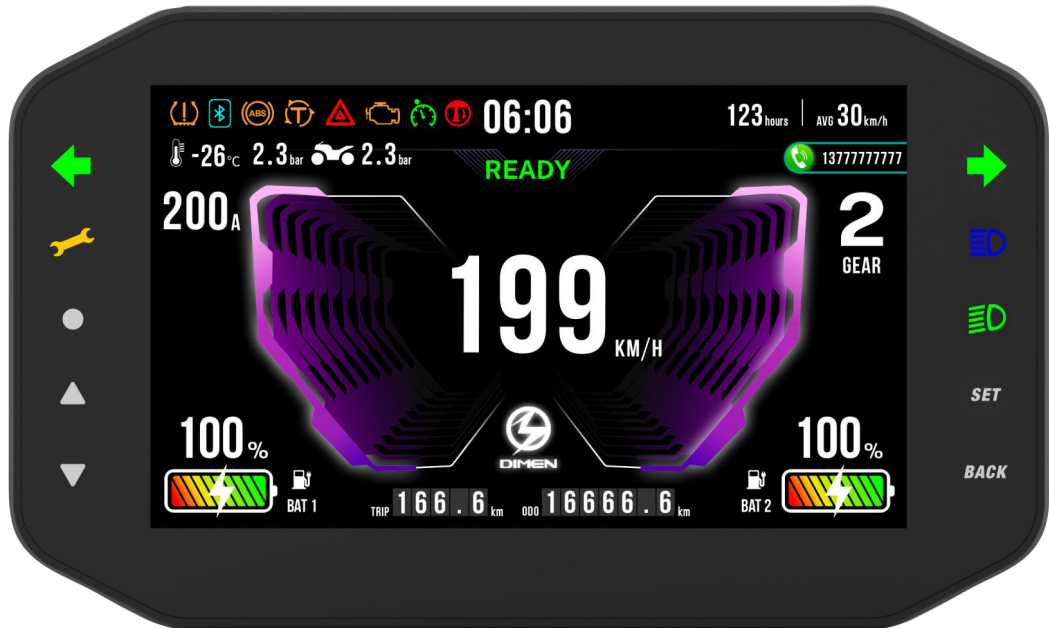

Night mode

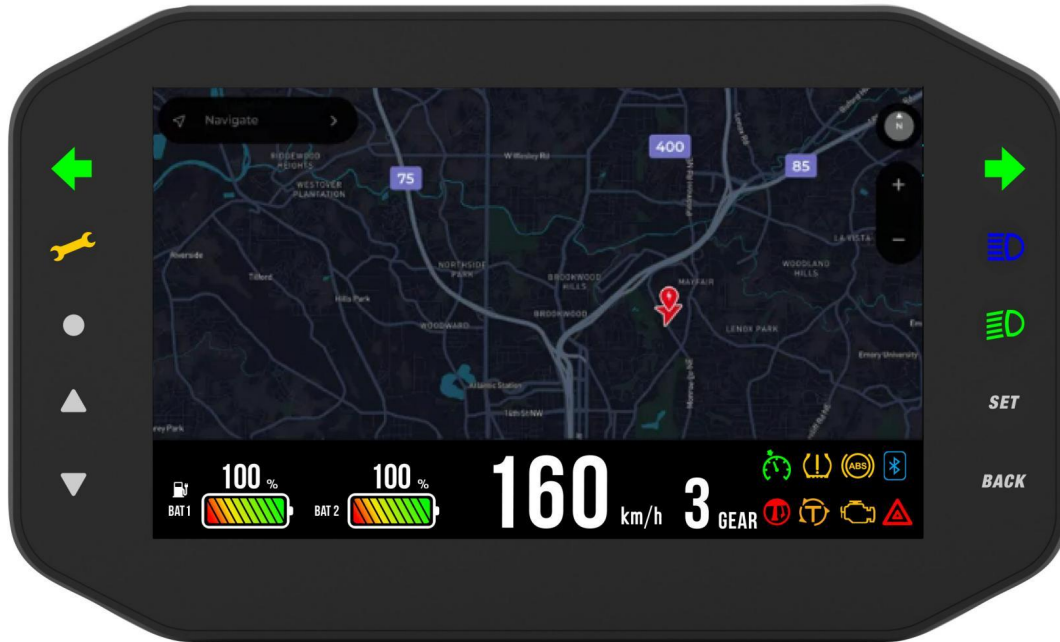

Navigation

EV Setting



Menu switch

Instrument has day and night mode, these can be achieved separately or automatically. When choosing Auto mode, instrument itself will choose day or night based on actual light intensity

车辆设置

手机蓝牙

记录仪设置

系统信息

界面切换
骑行模式
时钟设置
背光设置
单位设置
语言设置
胎压设置
倒车马力
牵引力控制
刹车断电

[舒适] [运动]

Driving mode:Normal or Sport

车辆设置

手机蓝牙

记录仪设置

系统信息

界面切换

骑行模式

时钟设置

背光设置

单位设置

语言设置

胎压设置

倒车马力

牵引力控制

刹车断电

00:48

Clock: set time.

车辆设置

手机蓝牙

记录仪设置

系统信息

界面切换

骑行模式

时钟设置

背光设置

单位设置

语言设置

胎压设置

倒车马力

牵引力控制

刹车断电

3



Backlight setting

车辆设置

手机蓝牙

记录仪设置

系统信息

界面切换
骑行模式
时钟设置
背光设置
单位设置
语言设置
胎压设置
倒车马力
牵引力控制
刹车断电

[公制] [英制]

KM-Miles

车辆设置

手机蓝牙

记录仪设置

系统信息

界面切换

骑行模式

时钟设置

背光设置

单位设置

语言设置

胎压设置

倒车马力

牵引力控制

刹车断电

[中文]

[EN]

Language: Chinese or English

车辆设置

手机蓝牙

记录仪设置

系统信息

界面切换

骑行模式

时钟设置

背光设置

单位设置

语言设置

胎压设置

倒车马力

牵引力控制

刹车断电

压力单位设置 [kpa]

前轮传感器学习 学习中

后轮传感器学习 未学习

Tyre pressure:

Unit of pressure is kpa, you can pair the pressure between sensor and instrument in this menu. There are 4 States:unpaired, in paring, paired,failed. If you dont know how to do the paring, contact dealers or distributors or DM after-sales.

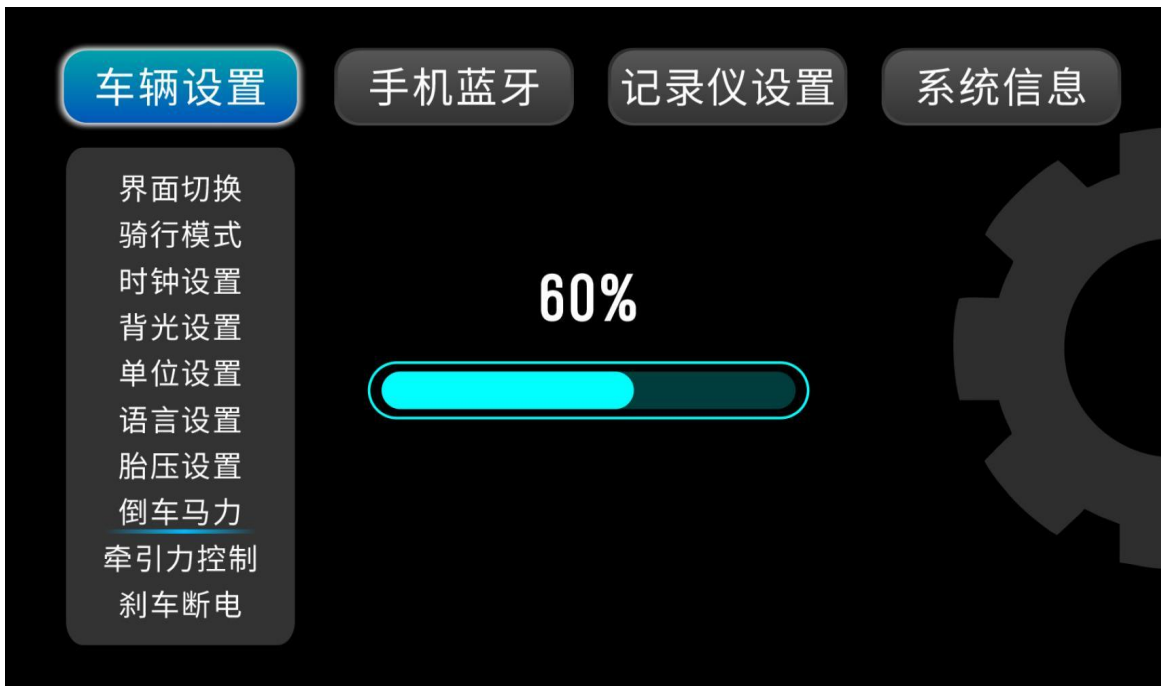

Astern/Reverse horsepower

The astern horsepower can be set here. For safety, It is recommended to choose a lower reverse horsepower when first use.

车辆设置

手机蓝牙

记录仪设置

系统信息

界面切换

骑行模式

时钟设置

背光设置

单位设置

语言设置

胎压设置

倒车马力

牵引力控制

刹车断电

[开启] [关闭]

TCS: Open or close

车辆设置

手机蓝牙

记录仪设置

系统信息

界面切换
骑行模式
时钟设置
背光设置
单位设置
语言设置
胎压设置
倒车马力
牵引力控制
刹车断电

[开启] [关闭]

EBS and no EBS: When you choosing EBS, energy braking system will be activated and cut the power to motor when you braking, it can help to low down the speed.

车辆设置

手机蓝牙

记录仪设置

系统信息

蓝牙连接: [开]

同步联系人: [200]

蓝牙名称: qj5inch-6f94

Bluetooth: After connecting the smart phone, it can synchronize the contacts from the phone, when call coming, the instrument can show contact information. At same time, it also can be used to play music、 power on & power off the EV.

车辆设置

手机蓝牙

记录仪设置

系统信息

请打开摄像头或检查摄像头



When instrument shows: Please check camera, please make sure if the camera is open or not. If already in open but still no frames, please contact dealers or distributors or DM after-sales.



Dash-cam has four functions: storing video, playing back, displaying pictures and changing Settings.



Can choose to play the recorded driving video, also can delete recorded driving videos.

车辆设置

手机蓝牙

记录仪设置

系统信息

2023/06/20 12:01:33



01:33/03:00

Playing record videos

You can drag the progress bar to change the video playback progress, and you can pause or continue playing the video



Photos: When incoming collision, collision sensor is activated, it will take an active picture, and you can choose to look back or delete the picture on this interface



Dash-can setting:

Open or close camera;

Adjust accuracy of the gyroscope (accuracy of collision), you can format the memory card here, remove all records

About: shows current system version

车辆设置

手机蓝牙

记录仪设置

系统信息

版本号:20210410QJv1.19

MCU版本:V0.0.9

System: Current Version

C. Switch assy

- ① Winker
- ② Enter
- ③ Back/Cancel
- ④ ABS
- ⑤ Cruise control
- ⑥ Down

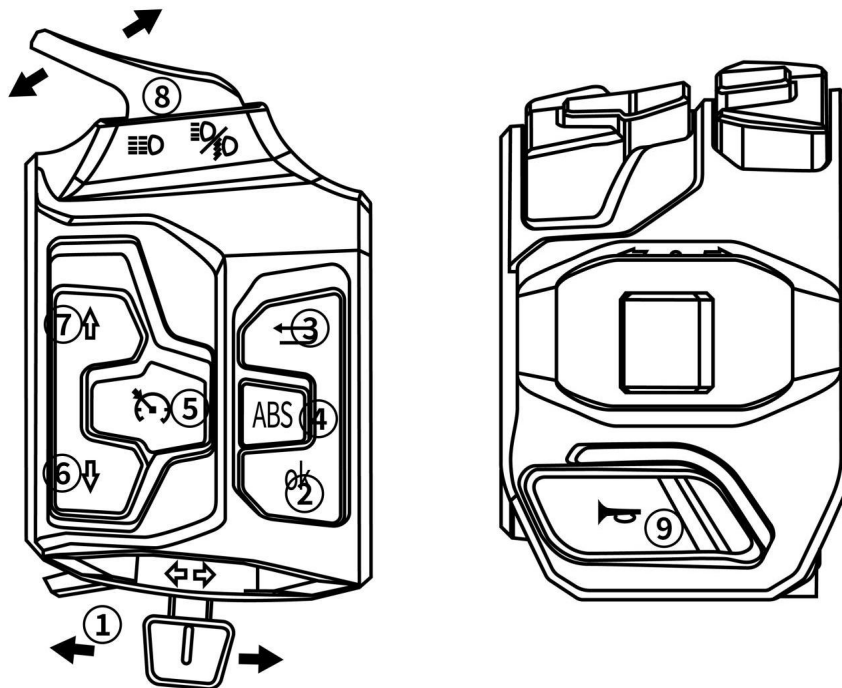

- ⑦ Up
- ⑧ Passing
- ⑨ Horn
- ⑩ Gear
- ⑪ Double blinking
- ⑫ Power on/off
- ⑬ Reverse/P

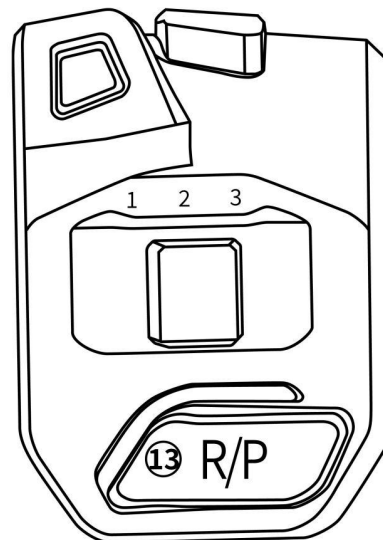
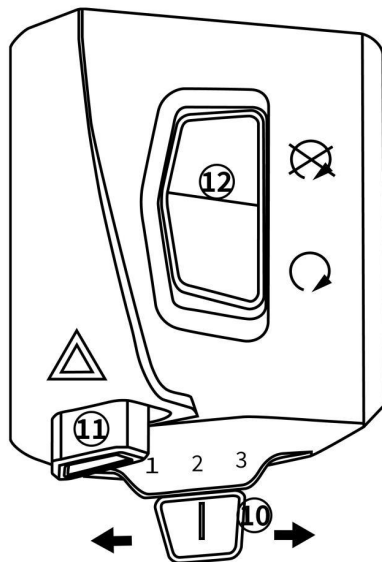

D. Key

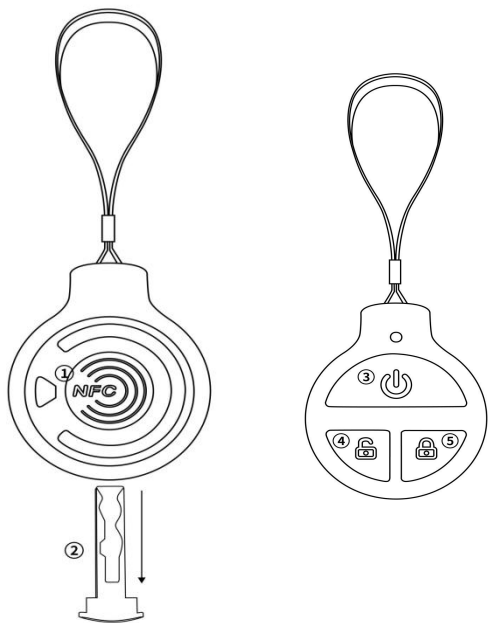

① NFC ② Key ③ Start ④ Unlock ⑤ Lock

E. Battery

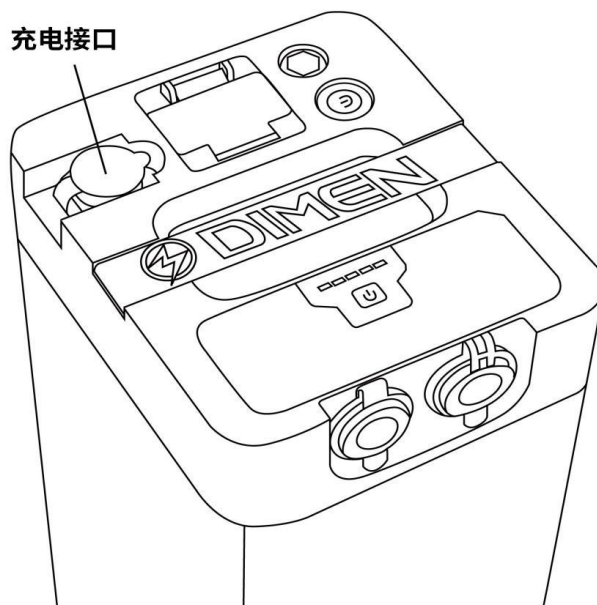

Open the cushion, take out the storage box, remove the connector from main harness, then take out the battery. The charger should be connected to battery first, then connected to power supply. If both the indicators on the charger and battery can light up, so charging is working.

To body charging socket.

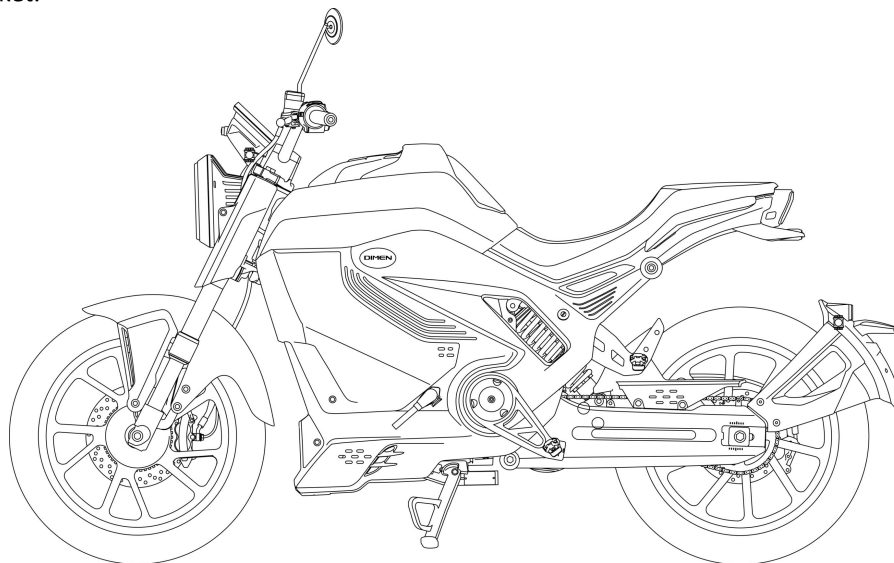

Put the battery into the EV and connected to main harness, put the storage box in position and close the cushion. Connecting the charger to power supply first, then connected to body charging socket. Then the green light will light up, so charging is working.

Battery indicator:

When charging, indicator always shows the bars, after the battery is fully charged, all lights up and no flashing.

When not in charging, the indicators will show the bars only when you pressing the button.

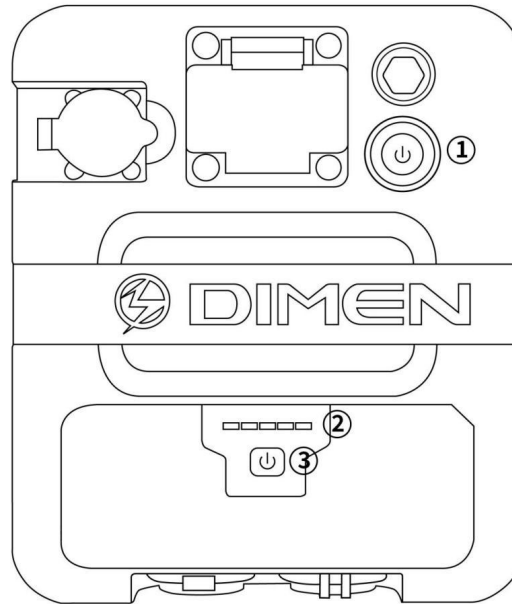

① 12v/5v power supply ② Indicator ③ Button

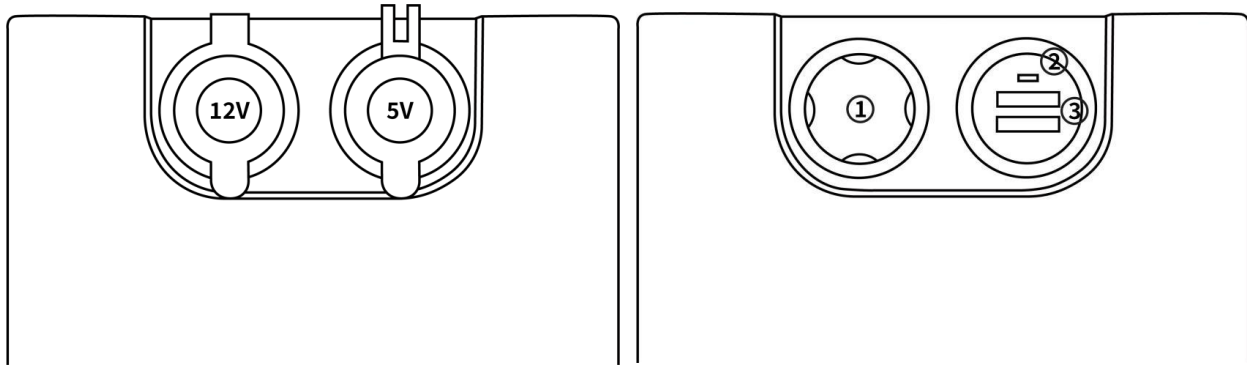

① 12v lighter /charging port ② Indicator ③ USB port

Low voltage power supply





This battery has 2 USB2.0 with 5V、 1 12V power supply. It can charge 3 electric device at same time.
Maximum current on 5V port:2A+2A; Maximum current on 8V port:8A(100W)

Battery use precaution

- Before charging, ensure the battery is original, don't use other brands and different types batteries;
- Ensure that the battery is in good station, no damage、leakage、overheat、water penetration、smoke etc;
- When using the battery for the first time, please do a full cycle before normal use to ensure that the actual capacity of the battery is as accurate as the power displayed on the mete;
- When daily use, please keep the battery power above 20% and charge it in time to extend the battery life;
- When daily use, it is not recommended to often drive the EV extremely, it can damage the battery;
- After the battery is used for a period, the actual capacity of the battery will deviate from the power displayed on the meter. Fully charge and discharge the battery regularly (no more than 3 months). The internal BMS system can balance the cells and calibrate the data automatically;
- It is recommended to check the battery socket and plug of the battery every two months to see whether the contact reed has carbon accumulation and oxidation (blackening). If these phenomena occur, please contact the dealers for repair;
- Batteries must not be rained or washed with water, nor soaked in water. If the EV wades, the water level shall not exceed the height of the battery bottom, otherwise the water will get into the battery, causing short-circuit and permanent failure of the battery. In this case, it is forbidden to recharge the EV or the battery, otherwise the battery may catch fire, burn or explode. Please take the battery to the dealer immediately for repair;
- For shipping safety, keep the charge is around 50% (30% by air). Since uncertain shipping/storage period and self consumption, please charge then in time after you receiving;
- If the battery connected to the EV, the EV itself will consume power, especially Alarm(about 3% / day), it is normal;
- If the EV/battery is needed to be stored for a long time, turn off the air switch or unplug the battery;
- If the EV/battery is needed to be stored for a long time, keep the ambient temperature of warehouse in Store the battery in 0℃~25℃, dont store the battery over 40℃, or the capacity of the battery will decay irreversibly;
- If the EV/battery is needed to be stored for a long time, it is recommended to keep the battery charge at 50%. if too full or too low, may cause the battery drained or chemistry damaged;
- Following is the technical standards of the self-consumption protection mode for the safe storage of lithium

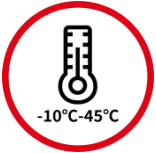
batteries:

- if the battery is not used for a long time, it can be stored in the EV (battery plug is not unplugged), the maximum safe storage time is 15 days, otherwise it may cause the battery to feed and cannot be restored.
- If the battery is not used for a long time, the power is not less than 50%, and is placed in the EV (unplug the battery), the maximum safe storage time is 2 months, otherwise it may cause the battery feed and cannot be restored.
- Do not store the battery in a place where there is a risk of falling;
- The battery is not covered with warranty by improper maintenance.

			
Battery use condition: -10°C-45°C	Avoid soaking the battery in water, beverages, and corrosive liquids or other liquids.	Prevent the battery far from heat sources, flames, and flammable and explosive gases (liquids).	Avoid metal material getting into the battery

At low temperatures, the available capacity of the battery will decrease inordinately. For example, the available capacity is 70% at -10°C, 85% at 0°C, and 100% at 25°C.



If abnormal conditions such as odor, overheating, and deformation occur, stop using the battery immediately, put it in open area, step away from the battery, and contact the dealer.

The battery is not a component that users can repair. If anything abnormal occurs, contact the dealer.

If the battery is disassembled without authorization, the user will not be able to enjoy the warranty service, and the battery may overheat, smoke, fire or explosion.

Charger use precautions

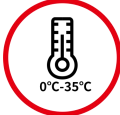
- Only can be used indoors;
- Do not charge the battery in a confined place or with high ambient temperature. Do not put the charger in barrel or truck when charging;
- When charging, connect the charger to power supply first, then battery; when stop charging, disconnect the power supply first, then battery;
- When charging to full, disconnect the charger in time, forbid to connect the charger and battery for a long time;
- When charging, stop immediately if odor, smoke and indicator flashing abnormal, contact dealer or after-sales center;
- Do not disassemble or repair the charger without authorization;
- When replacing the charger, make sure the new charger can match the battery;

		
<p>Please use the original charger to charge the battery, do not use other brands or different types of chargers to charge the battery.</p>	<p>Charge the battery at an ambient temperature of 0°C to 35°C.</p>	<p>Do not charge the battery for more than 8 hours; otherwise, the service life of the battery will be affected.</p>

- Early charging speed is fast, late charging speed is slow, this is because the logic set for charging safety, this is normal;
- In winter, if the outdoor temperature is low, below 0 °C, the charging will be suspended, which is a normal phenomenon. Please charge at the appropriate ambient temperature to ensure the charging efficient.

In the charging process, aluminum shell on the chargers will produce thermal effect, the surface temperature is high, this is a normal phenomenon, please rest assured to use, and avoid children touching the charger.

How to start the EV

- Step 1: Please check all parts of the EV before riding. If there is any abnormality, please timely repair or contact the authorized dealer for repair.
- Step 2: Put on the helmet, on the EV, and unlock the EV using NFC/ Bluetooth /APP. If NFC/ Bluetooth /APP fails, you can use the spare key to start the EV;
 - By NFC: Put the key on the sensing area, the bike will be powered on;

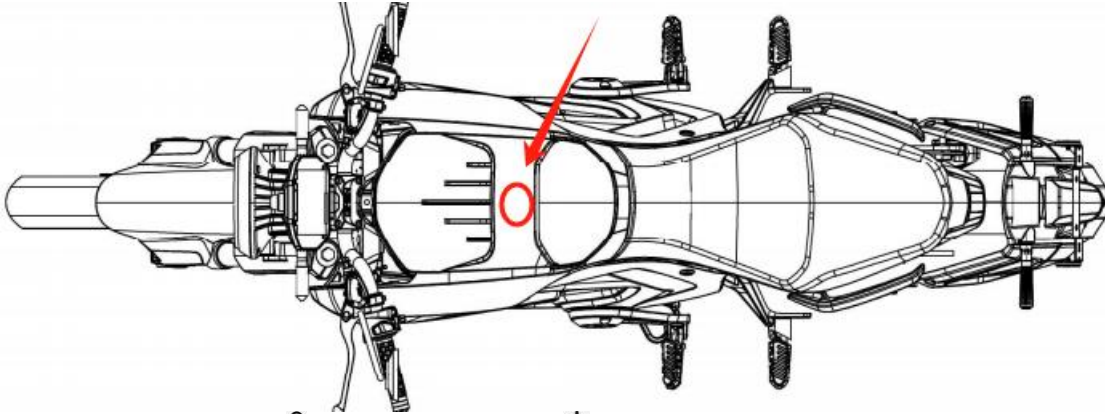

- By remote keys: Press the  for 1 time and press  for 3 times, and the bike will be powered on;

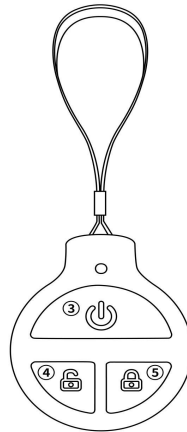

- By mechanical key: Use the mechanical key to unlock and power the bike through the lock in the storage box.
- Step 3: Lift the side stand, and the display will show "READY".

Riding Guidance

A. Preparations and precautions

- Keep drunk away from driving;
- Driving skills are necessary, whatever if you already skilled at other EVs, please spend some time to familiar with DP-03;
- We require all drivers to take THE driving courses certified by the local government and get relevant certification;
- If it is first time for you to drive this product, we strongly urge you to read the user manual carefully;
- Confirm that you have fully understood all safety information;
- Understand all the functions of the EV;
- Please make sure that you are healthy and in good condition;
- Helmet, goggles and riding clothing are necessary, they can help you reduce hurt when accident;
- Don't drive after drinking or taking drugs.

B. Checking before riding

- When it is first time you receive this product, check the EV carefully. Anything damaged or no function, contact dealer for help.
- Before riding, check the items as following
 - Check whether the throttle rotates stably and flexibly.
 - Check whether the left/right switches can work properly;
 - Make sure the tire pressure is correct. Recommended tire pressure: Front: 250kpa (36psi); rear: 250kpa (36psi) for the rear wheel.
 - Check if the tire surface is clean and in good station. No breaks, damage, wear, or foreign objects piercing or sticking to other objects.
 - Tread depth is sufficient (0.8mm).
 - Whether the engine check light is shown on the dashboard.

- Whether the battery is in good state.
- Whether headlights, taillights, stop lights and turn signals work properly.
- Whether the horn is working properly.
- Rear mirrors are clean and adjusted to the proper angle.
- Whether the brake oil is sufficient, and whether the brake handle and brake system can work properly.
- Anything wrong or abnormal, please contact dealers.

C. Road condition and driving guidance

- Precaution: Overloading or improper loading may affect this products performance, resulting in serious casualties. Please comply with all load limits and other load information in this manual.
- Loading: The DP-03 has a maximum capacity of 320 kg, including the weight of the driver, passengers and all EV itself. DP-03 should be used for you and your passengers first. However, if you want to load more, we recommend using a saddle bag. Please consult your dealer for the correct loading method and capacity range for the DP-03. Incorrect loading may affect the stability and handling of the DP-03. Even if the DP-03 is loaded correctly, you should drive within a safe speed.
- When loading, please observe the following rules:
 - Check both front and rear tires in good state;
 - If you change the normal loading capacity, it may be necessary to adjust the way the cargo is hung;
 - In order to prevent the goods from loosening, please ensure that all goods are securely tied;
 - When loading, try to make the center g gravity is alignment with the center of gravity of the EV;
 - Distribute the weight of the goods evenly on both sides of the body.

D. Braking

- Before driving the EV, it is necessary to check whether brake handles can work properly.
- Braking too hard may cause the wheels blocked and slipping sideways, and reducing control of the motorcycle. In this case, release the brake handle, continue driving forward until you regain the control, and then tap the brake again. EV

equipped with CBS can better distribute braking force, EV equipped with TCS can avoid the wheel to be blocked and regain control. Even if the EV you are driving equipped with CBS and TCS, you should still use the brakes reasonably according to the road conditions to avoid some special cases, electronic assistance system failure, resulting in safety problems.

- Slow down as much as possible before turning. Avoid braking while turning, as braking may cause one or both wheels to slip, reducing control of the motorcycle.
- The ability to turn and brake in emergency situations is an important driving skill. We recommend attending some motorcycle training courses to master these skills.
- When driving on wet, rainy or soft ground, the motorcycle's maneuverability and braking ability will be reduced. In this situation, should slow down the speed; Sudden acceleration, braking or cornering may cause the motorcycle to lose control. For your safety, please brake, accelerate, or turn carefully. Even when driving a EV equipped with TCS, you should still slow down to avoid rapid acceleration and deceleration, in order to avoid the failure of the electronic assistance system in some special cases, causing safety problems.
- On long steep slopes, frequent intermittent use of the brake or continuous braking may overheat the brake and reduce its working effect.
- When riding, if the hand is on the brake handle for a long time, it may turn on the stop light by mistake and send out wrong signals to other drivers; It may also overheat the brakes, reducing braking effectiveness

E. Parking

- Drop the side stand, the icon "READY" on the instrument will disappear. You can power off the bike by NFC/Bluetooth/APP/key.
- Do not park electric motorcycles in lobbies, escape stairs, life passageways, or safety exits. These areas are reserved for emergency use only.

Maintenance

A. Maintenance of chain

- Scheduled maintenance
 - The chain is wearing parts and the wear is gradual and imperceptible. So check the chain regularly is necessary. If the chain can't be corrected, please replace it in time to avoid accident.
 - The chain should be maintained every 500KM、high way driving、after driving on rain day, cause these will affect the lubricating. In parallel, the lifetime of chain also be affected by ultraviolet ray、rain、dust, so need to clean and lubricate the chain in time;

- Cleaning
 - Prepare the following tools: chain cleaner, towel, brush and sewage basin before cleaning the chain
 - In order for each chain to be fully sprayed with the chain cleaner, slowly turn the wheel slowly while spraying the cleaner on. In order to prevent other parts from cleaner, please use a towel to block. In addition, when spraying a large amount of cleaner, please place the sewage basin below.
 - After the chain is fully sprayed with cleaning agent, if there is dirt hard to remove, please use a brush to clean the dirt. Steel brush will damage the chain, do not use. Even if you use a soft brush, it may hurt the oil film. Please use it with caution. After scrubbing the chain with a brush, wrap the chain in a towel and wipe it clean.
 - During the operation, when turning the wheel, please pay attention: do not be caught by the chain tooth.

- Lubrication
 - When lubricating the chain, please choose chain oil containing lubrication and oil film protection. When spraying lubricating oil, please prepare the following tools: chain oil, towel, sewage basin.
 - In order to lubricate each tooth of the chain, slowly turn the wheel at a distance of 3 to 10cm each time, and evenly spray the chain with chain oil. To prevent other parts from the oil, please prepare a towel. After spraying, excess chain oil will drip off. Therefore, please place the sewage basin below. After the chain is evenly sprayed

with lubricating oil, spray a little oil on the tower and use it to wipe off excess oil from the chain.

- Adjustment
 - Adjust the tension before driving, for this model, the clearance is 10mm.
 - Caution: the tension of chain must not too tight or loose, if too loose, the chain may pill off the chain-wheel; if too tight, the chain will suffer too much burden; both will cause uncomfortable driving experience.

- Replacement
 - The lifetime of chain under good maintenance is 2000km, based on actual situation.
 - Suggest you to go to the dealers or maintenance spots authorized by DIMEN.

B. Maintenance list

Maintenance list	Mileage/Time (which occur first)							
	500 km/1 month	1000km/2 months	4800 KM/6 months	9600km / 12 months	14400 km/18 months	19300 km/24 months	24100 km/ 30 months	
Throttle	√	√	√	√	√	√	√	√
Front brake system	√	√	√	√	√	√	√	√
Rear brake system	√	√	√	√	√	√	√	√
Brake tubes and screws	√	√	√	√	√	√	√	√
Brake oil				√		√		√

All functional buttons	√	√	√	√	√	√	√	√
Lights	√	√	√	√	√	√	√	√
Side stand	√	√	√	√	√	√	√	√
Front suspension , front fork	√	√	√	√	√	√	√	√
Tighten parts	√	√	√	√	√	√	√	√
Tires	√	√	√	√	√	√	√	√
Wheel	√	√	√	√	√	√	√	√
Steering bearing	√	√	√	√	√	√	√	√
Battery	√	√	√	√	√	√	√	√
Motor	√	√	√	√	√	√	√	√
All check should be done by dealers authorized by DIMEN or distributors.								
Maintenance list	Mileage/Time (which occur first)							

C. Clearing

- Before cleaning the EV, turn off the power and remove the battery.
- You can scrub the EV with a mixture of water and neutral detergent.
- After cleaning the vehicle, wipe the surface with a soft cloth.
- Do not use high-pressure water gun to wash the sides and interior of the body directly. Electronic components such

as the charging socket and controller are located in the side cover above the pedal. Do not rinse directly.

D. Storage

- Please store the vehicle in a flat, sturdy, ventilated and dry place. Please avoid sun and rain on the vehicle to reduce damage or aging of the components. For long-term storage of the vehicle, refer to the battery information in this manual.
- When the EV is used again after long-term storage, the battery should be fully charged.

Troubleshooting

Phenomenon	Cause	Countermeasures
The EV cant be powered on	No power or control unit fails to work	<ol style="list-style-type: none"> 1. Check connectors are well connected 2. Check battery (indicator, BMS data) 3. Check controller (indicator)
The EV can be powered on, but motor can not rotate	<ol style="list-style-type: none"> 1. EV in braking 2. EV in Parking 3. Side stand not in correct position 4. Start button fails to work 5. Brake level not in correct position 	<ol style="list-style-type: none"> 1. Check if the EV in baking 2. Down the side stand 3. Contact aftersales for help
Low range	<ol style="list-style-type: none"> 1. Low battery charge 2. Low tire pressure 3. Brake too often, overloading 4. Cells in battery are decayed 	<ol style="list-style-type: none"> 1. Check if the charger in can work properly 2. Check tires pressure before riding 3. Be in good driving habits 4. Replace the battery 5. It is normal.
Battery can not be charged	<ol style="list-style-type: none"> 1. Charger doesnt be plugged in position 2. Temperature in battery is too low 3. Temperature in battery is too high 4. Check BMS data. 	<ol style="list-style-type: none"> 1. Check if the plug is loose 2. Waiting for the battery back to chargeable temperature
No power from USB	<ol style="list-style-type: none"> 1. The plug is not inserted to the socket well 2. Cable is not up up to standard 	<ol style="list-style-type: none"> 1. Check if the plug well inserted to the socket 2. Change the cables 3. Contact aftersales for help

Definition of controller error code		Blinking frequency
Over-voltage protection	Battery voltage over setting	1
Under voltage protection	Battery voltage under setting	2
Over-current protection	Short circuit in motor phase lines or phase lines to the ground	3
Motor block protection	Motor blocked exceeds setting	4
Hall sensor protection	Hall signal abnormal	5
MOSFET protection	Abnormal situation was found when MOSFET self-checking	6
Open-phase protection	One of phase is open	7
Self checking protection	Abnormal situation is found when self-checking	10
High temperature protection on controller	Working temperature exceeds setting	11
Turn the car for protection	Signals from throttle is abnormal	12
High temperature protection on motor	Working temperature in motor exceeds setting	13
Throttle not in position	Re-operate the throttle and release it fully	14
Controller braking	Controller in braking	15

MAINTENANCE RECORD:

Content:

Date :

MAINTENANCE RECORD:

Content:

Date :

MAINTENANCE RECORD:

Content:

Date :

MAINTENANCE RECORD:

Content:

Date :

MAINTENANCE RECORD:

Content:

Date :

MAINTENANCE RECORD:

Content:

Date :

Dimentro

<https://www.dimentro.com>

WUXI DIANMENG TECHNOLOGY CO.,LTD

NO.268 HOUXIN ROAD, WUXI, JIANGSU, P.R.CHINA

E-mail: info@dimentro.com

DIMEN FRANCE

Cellule G9, Parc Dynamikun 78300 Poissy

E-mail: longkai.w@dimentro.com

DIMEN INDONESIA

Ruko Northridge Business Center, blok A3/2 and A3/3,

BSD City, Serpong-Tangerang 15331

E-mail: marketing@dimen-indonesia.com